

रोल नं.
Roll No.

--	--	--	--	--	--	--

परीक्षार्थी कोड को उत्तर-पुस्तिका के मुख-पृष्ठ पर अवश्य लिखें।

Candidates must write the Code on the title page of the answer-book.

- कृपया जाँच कर लें कि इस प्रश्न-पत्र में मुद्रित पृष्ठ 16 हैं।
- प्रश्न-पत्र में दाहिने हाथ की ओर दिए गए कोड नम्बर को छात्र उत्तर-पुस्तिका के मुख-पृष्ठ पर लिखें।
- कृपया जाँच कर लें कि इस प्रश्न-पत्र में 26 प्रश्न हैं।
- कृपया प्रश्न का उत्तर लिखना शुरू करने से पहले, प्रश्न का क्रमांक अवश्य लिखें।
- इस प्रश्न-पत्र को पढ़ने के लिए 15 मिनट का समय दिया गया है। प्रश्न-पत्र का वितरण पूर्वाह्न में 10.15 बजे किया जाएगा। 10.15 बजे से 10.30 बजे तक छात्र केवल प्रश्न-पत्र को पढ़ेंगे और इस अवधि के दौरान वे उत्तर-पुस्तिका पर कोई उत्तर नहीं लिखेंगे।
- Please check that this question paper contains 16 printed pages.
- Code number given on the right hand side of the question paper should be written on the title page of the answer-book by the candidate.
- Please check that this question paper contains 26 questions.
- **Please write down the Serial Number of the question before attempting it.**
- 15 minute time has been allotted to read this question paper. The question paper will be distributed at 10.15 a.m. From 10.15 a.m. to 10.30 a.m., the students will read the question paper only and will not write any answer on the answer-book during this period.

भौतिक विज्ञान (सैद्धान्तिक)

PHYSICS (Theory)

निर्धारित समय : 3 घण्टे

Time allowed : 3 hours

अधिकतम अंक : 70

Maximum Marks : 70

55/2/3

1

P.T.O.



सामान्य निर्देश:

- (i) सभी प्रश्न अनिवार्य हैं। इस प्रश्न-पत्र में कुल 26 प्रश्न हैं।
- (ii) इस प्रश्न-पत्र के पाँच भाग हैं: खण्ड अ, खण्ड ब, खण्ड स, खण्ड द और खण्ड य।
- (iii) खण्ड अ में पाँच प्रश्न हैं, प्रत्येक का एक अंक है। खण्ड ब में पाँच प्रश्न हैं, प्रत्येक के दो अंक हैं। खण्ड स में बारह प्रश्न हैं, प्रत्येक के तीन अंक हैं। खण्ड द में चार अंक का एक मूल्याधारित प्रश्न है और खण्ड य में तीन प्रश्न हैं, प्रत्येक के पाँच अंक हैं।
- (iv) प्रश्न-पत्र में समग्र पर कोई विकल्प नहीं है। तथापि, दो अंकों वाले एक प्रश्न में, तीन अंकों वाले एक प्रश्न में और पाँच अंकों वाले तीनों प्रश्नों में आन्तरिक चयन प्रदान किया गया है। ऐसे प्रश्नों में आपको दिए गए चयन में से केवल एक प्रश्न ही करना है।
- (v) जहाँ आवश्यक हो आप निम्नलिखित भौतिक नियतांकों के मानों का उपयोग कर सकते हैं :

$$c = 3 \times 10^8 \text{ m/s}$$

$$h = 6.63 \times 10^{-34} \text{ Js}$$

$$e = 1.6 \times 10^{-19} \text{ C}$$

$$\mu_0 = 4\pi \times 10^{-7} \text{ T m A}^{-1}$$

$$\epsilon_0 = 8.854 \times 10^{-12} \text{ C}^2 \text{ N}^{-1} \text{ m}^{-2}$$

$$\frac{1}{4\pi\epsilon_0} = 9 \times 10^9 \text{ N m}^2 \text{ C}^{-2}$$

$$\text{इलेक्ट्रॉन का द्रव्यमान} = 9.1 \times 10^{-31} \text{ kg}$$

$$\text{न्यूट्रॉन का द्रव्यमान} = 1.675 \times 10^{-27} \text{ kg}$$

$$\text{प्रोटॉन का द्रव्यमान} = 1.673 \times 10^{-27} \text{ kg}$$

$$\text{आवोगाद्रो संख्या} = 6.023 \times 10^{23} \text{ प्रति ग्राम मोल}$$

$$\text{बोल्ट्ज़मान नियतांक} = 1.38 \times 10^{-23} \text{ JK}^{-1}$$

General Instructions :

- (i) *All questions are **compulsory**. There are **26** questions in all.*
- (ii) *This question paper has **five** sections : Section A, Section B, Section C, Section D and Section E.*
- (iii) *Section A contains **five** questions of **one** mark each, Section B contains **five** questions of **two** marks each, Section C contains **twelve** questions of **three** marks each, Section D contains one value based question of **four** marks and Section E contains **three** questions of **five** marks each.*
- (iv) *There is no overall choice. However, an internal choice has been provided in **one** question of **two** marks, **one** question of **three** marks and all the **three** questions of **five** marks weightage. You have to attempt only **one** of the choices in such questions.*
- (v) *You may use the following values of physical constants wherever necessary :*

$$c = 3 \times 10^8 \text{ m/s}$$

$$h = 6.63 \times 10^{-34} \text{ Js}$$

$$e = 1.6 \times 10^{-19} \text{ C}$$

$$\mu_0 = 4\pi \times 10^{-7} \text{ T m A}^{-1}$$

$$\epsilon_0 = 8.854 \times 10^{-12} \text{ C}^2 \text{ N}^{-1} \text{ m}^{-2}$$

$$\frac{1}{4\pi\epsilon_0} = 9 \times 10^9 \text{ N m}^2 \text{ C}^{-2}$$

$$\text{Mass of electron} = 9.1 \times 10^{-31} \text{ kg}$$

$$\text{Mass of neutron} = 1.675 \times 10^{-27} \text{ kg}$$

$$\text{Mass of proton} = 1.673 \times 10^{-27} \text{ kg}$$

$$\text{Avogadro's number} = 6.023 \times 10^{23} \text{ per gram mole}$$

$$\text{Boltzmann constant} = 1.38 \times 10^{-23} \text{ JK}^{-1}$$



खण्ड अ
SECTION A

1. क्या किसी सूक्ष्मदर्शी की आवर्धन क्षमता उपयोग किए गए प्रकाश के वर्ण पर निर्भर करती है ? अपने उत्तर की पुष्टि कीजिए । 1

Does the magnifying power of a microscope depend on the colour of the light used ? Justify your answer.

2. लाल वर्ण का प्रकाश आपतित होने पर कोई प्रकाश-सुग्राही पृष्ठ प्रकाश-विद्युत्-इलेक्ट्रॉन उत्सर्जित करता है । इसी पृष्ठ पर नीले वर्ण के प्रकाश को आपतित कराने पर क्या यह पृष्ठ प्रकाश-विद्युत्-इलेक्ट्रॉन उत्सर्जित करेगा ? कारण दीजिए । 1

A photosensitive surface emits photoelectrons when red light falls on it. Will the surface emit photoelectrons when blue light is incident on it ? Give reason.

3. किसी OR गेट का लॉजिक (तर्क) प्रतीक खींचिए और इसकी सत्यमान सारणी लिखिए । 1
Draw logic symbol of an OR gate and write its truth table.

4. आरेख में दर्शाए अनुसार किसी बिन्दु 'O' पर कोई बिन्दु आवेश Q स्थित है । जब Q (i) धनात्मक, और (ii) ऋणात्मक आवेशित है, तो क्या बिन्दु B पर विभव V_B की तुलना में बिन्दु A पर विभव V_A अधिक है, कम है अथवा बराबर है ? 1

O• A• B•

A point charge Q is placed at point 'O' as shown in the figure. Is the potential at point A, i.e. V_A , greater, smaller or equal to potential, V_B , at point B, when Q is (i) positive, and (ii) negative charge ?

O• A• B•

5. वैद्युत विद्युत्शीलता ϵ और चुम्बकशीलता μ के किसी माध्यम में विद्युत्-चुम्बकीय तरंगों की चाल के लिए व्यंजक लिखिए । 1

Write the expression for speed of electromagnetic waves in a medium of electrical permittivity ϵ and magnetic permeability μ .



खण्ड ब
SECTION B

6. यह दर्शाने के लिए दर्पण समीकरण का उपयोग कीजिए कि किसी अवतल दर्पण के f और $2f$ के बीच स्थित किसी बिम्ब का प्रतिबिम्ब $2f$ से परे बनता है ।

2

अथवा

- (a) उस अवस्था (शर्त) का उल्लेख कीजिए जिसमें किसी खगोलीय दूरबीन (टेलीस्कोप) में प्रचुर (बृहत्) आवर्धन प्राप्त किया जा सकता है ।
- (b) अपवर्ती दूरबीन (टेलीस्कोप) की तुलना में परावर्ती दूरबीन (टेलीस्कोप) को अधिक वरीयता दिए जाने की व्याख्या के लिए दो कारण दीजिए ।

2

Use the mirror equation to show that an object placed between f and $2f$ of a concave mirror forms an image beyond $2f$.

OR

- (a) State the condition under which a large magnification can be achieved in an astronomical telescope.
- (b) Give two reasons to explain why a reflecting telescope is preferred over a refracting telescope.

7. यंग के द्विझिरी प्रयोग में परदे के उस बिन्दु पर तीव्रता ज्ञात कीजिए जहाँ पर व्यतिकरण करने वाली तरंगों के बीच पथान्तर (i) $\lambda/6$, और (ii) $\lambda/2$ है ।

2

Find the intensity at a point on a screen in Young's double slit experiment where the interfering waves have a path difference of (i) $\lambda/6$, and (ii) $\lambda/2$.

8. परिपथ आरेख की सहायता से प्रकाश-चालकीय डायोड (फोटोडायोड) की क्रियाविधि का वर्णन कीजिए ।

2

Describe, with the help of a circuit diagram, the working of a photodiode.



9. संचार की प्रसारण विधा और स्थल-स्थल संचरण विधा के बीच विभेदन कीजिए और प्रत्येक का एक उदाहरण दीजिए । 2
- Distinguish between broadcast mode and point-to-point mode of communication and give one example for each.
10. वोल्टता के किसी ac स्रोत से कोई प्रकाश बल्ब और कोई परिनालिका श्रेणी में संयोजित हैं । व्याख्या कीजिए कि परिनालिका के भीतर कोई लोहे की छड़ ले जाने पर प्रकाश बल्ब की चमक किस प्रकार प्रभावित होगी । 2
- A light bulb and a solenoid are connected in series across an ac source of voltage. Explain, how the glow of the light bulb will be affected when an iron rod is inserted in the solenoid.

खण्ड स

SECTION C

11. एक प्रोटॉन और एक α -कण किसी चुम्बकीय क्षेत्र के लम्बवत् गमन कर रहे हैं । इनके द्वारा चले गए वृत्ताकार पथों की त्रिज्याओं का अनुपात ज्ञात कीजिए जब दोनों (i) के वेग समान हैं, और (ii) की गतिज ऊर्जाएँ समान हैं । 3
- A proton and an α -particle move perpendicular to a magnetic field. Find the ratio of radii of circular paths described by them when both have (i) equal velocities, and (ii) equal kinetic energy.
12. (i) व्यतिकरण में उत्पन्न फ्रिन्जों, और (ii) एकल झिरी के कारण उत्पन्न विवर्तन बैण्डों के तीव्रता वितरणों को आरेख खींचकर दर्शाइए । व्यतिकरण और विवर्तन की परिघटनाओं के बीच विभेदनकारी दो बिन्दु लिखिए । 3
- Draw the intensity distributions for (i) the fringes produced in interference, and (ii) the diffraction bands produced due to single slit. Write two points of difference between the phenomena of interference and diffraction.



13. स्थिर-विद्युतिकी में गाउस नियम का प्रयोग करके एकसमान आवेशित अनन्त समतल शीट के कारण विद्युत्-क्षेत्र तीव्रता के लिए व्यंजक व्युत्पन्न कीजिए । यदि इस शीट के समान्तर कोई अन्य सर्वसम शीट रख दी जाए, तो यह दर्शाइए कि इन दोनों शीटों के मध्य के क्षेत्र में कोई विद्युत्-क्षेत्र नहीं होता ।

3

Using Gauss's law in electrostatics, deduce an expression for electric field intensity due to a uniformly charged infinite plane sheet. If another identical sheet is placed parallel to it, show that there is no electric field in the region between the two sheets.

14. दिए गए परिपथ में, स्थायी धारा के साथ, संधारित्र के सिरों पर विभव पात तथा इसमें संचित आवेश परिकलित कीजिए ।

3

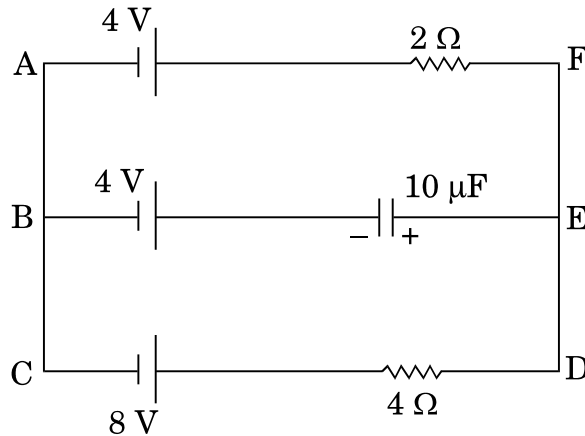

In the given circuit, with steady current, calculate the potential drop across the capacitor and the charge stored in it.

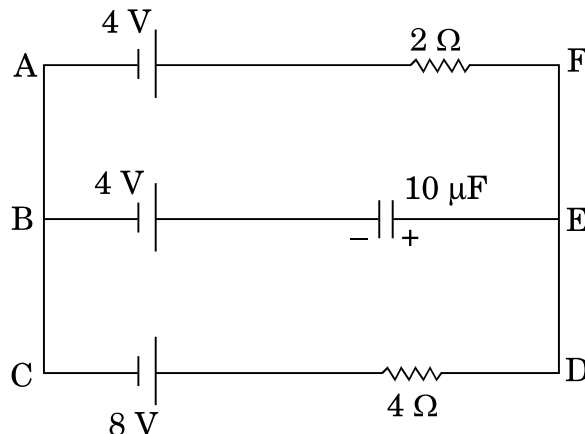

15. (a) विद्युत्-चुम्बकीय तरंगें किस प्रकार उत्पन्न होती हैं ? व्याख्या कीजिए ।
(b) कोई समतल विद्युत्-चुम्बकीय तरंग किसी माध्यम में धनात्मक z-दिशा के अनुदिश गतिमान है । इस विद्युत्-चुम्बकीय तरंग को दोलायमान विद्युत् और चुम्बकीय क्षेत्रों की दिशाओं को दर्शाते हुए चित्रित कीजिए ।

3

- (a) How are electromagnetic waves produced ? Explain.
(b) A plane electromagnetic wave is travelling through a medium along the +ve z-direction. Depict the electromagnetic wave showing the directions of the oscillating electric and magnetic fields.

16. (a) किसी रेडियोएक्टिव पदार्थ के क्षयांक और अर्ध आयु के बीच संबंध व्युत्पन्न कीजिए ।
(b) कोई रेडियोएक्टिव तत्त्व 1000 वर्ष में घटकर अपने प्रारम्भिक द्रव्यमान का 25% रह जाता है । इसकी अर्ध आयु ज्ञात कीजिए ।

3

- (a) Derive the relation between the decay constant and half life of a radioactive substance.
(b) A radioactive element reduces to 25% of its initial mass in 1000 years. Find its half life.

17. त्रिज्या R के किसी धात्विक गोले के पृष्ठ पर आवेश Q एकसमान रूप से वितरित है । किसी बिन्दु $0 < x < R$ पर विद्युत्-क्षेत्र (E) और विद्युत् विभव (V) के लिए व्यंजक प्राप्त कीजिए । ग्राफ़ खींचकर x के साथ, जबकि $0 < x < 2R$ है, E और V का विचरण दर्शाइए ।

3

A charge Q is distributed uniformly over a metallic sphere of radius R. Obtain the expressions for the electric field (E) and electric potential (V) at a point $0 < x < R$.

Show on a plot the variation of E and V with x for $0 < x < 2R$.



18. बोर के अभिगृहीतों का उपयोग करके, हाइड्रोजन परमाणु की n वीं कक्षा में गतिमान इलेक्ट्रॉन की कक्षीय अवधि के लिए व्यंजक व्युत्पन्न कीजिए ।

3

Using Bohr's postulates, derive the expression for the orbital period of the electron moving in the n^{th} orbit of hydrogen atom.

19. (a) समान तीव्रता परन्तु विभिन्न आवृत्तियों के आपतित विकिरणों के लिए संग्राहक विभव के साथ प्रकाश-विद्युत् धारा के विचरण को दर्शाने के लिए ग्राफ़ खींचिए ।

- (b) इस ग्राफ़ से प्रेक्षणों की व्याख्या के लिए आइन्स्टाइन के प्रकाश-विद्युत् समीकरण का उपयोग कीजिए ।

- (c) यदि आवृत्ति को समान रखते हुए आपतित विकिरणों की तीव्रता को परिवर्तित किया जाए, तो आप क्या परिवर्तन देखेंगे ?

3

- (a) Draw a plot showing the variation of photoelectric current with collector potential for different frequencies but same intensity of incident radiation.

- (b) Use Einstein's photoelectric equation to explain the observations from this graph.

- (c) What change will you observe if intensity of incident radiation is changed but the frequency remains the same ?

20. बायो-सावर्ट नियम का उपयोग करके त्रिज्या R के किसी धारावाही वृत्ताकार पाश के अक्ष के किसी बिन्दु (x) पर चुम्बकीय क्षेत्र के लिए व्यंजक व्युत्पन्न कीजिए । इस बिन्दु पर चुम्बकीय क्षेत्र की दिशा किस प्रकार निर्धारित की जाती है ?

3

अथवा



चित्र में तीन अनन्त लम्बाई के सीधे समानान्तर धारावाही चालक दर्शाए गए हैं। ज्ञात कीजिए :

- (i) चालक 1 पर स्थित बिन्दु A पर कुल चुम्बकीय क्षेत्र का परिमाण तथा दिशा।
- (ii) चालक 2 पर चुम्बकीय बल।

3

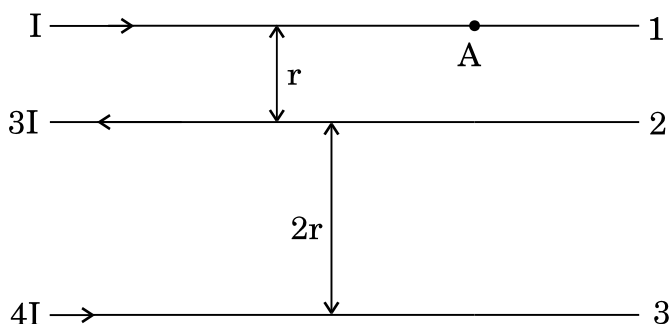

Using Biot-Savart law, deduce the expression for the magnetic field at a point (x) on the axis of a circular current carrying loop of radius R. How is the direction of the magnetic field determined at this point ?

OR

The figure shows three infinitely long straight parallel current carrying conductors. Find the

- (i) magnitude and direction of the net magnetic field at point A lying on conductor 1,
- (ii) magnetic force on conductor 2.

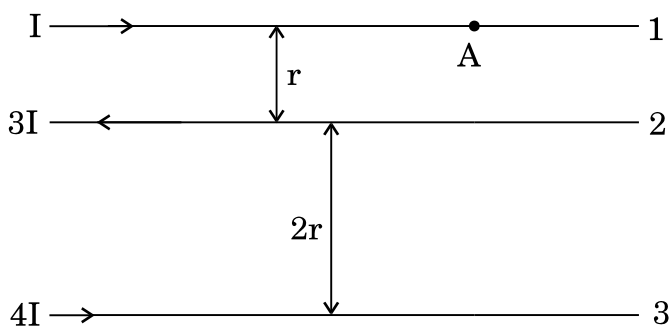

55/2/3

10



21. आकाश तरंग संचरण क्या है ? कौन-सी संचार व्यवस्थाएँ आकाश तरंगों का उपयोग करती हैं ? ऊँचाई h के प्रेषण एन्टेना का 'रेडियो क्षितिज' कितना होता है ? 40 MHz से अधिक आवृत्तियों के लिए आकाश तरंग संचरण क्यों उपयुक्त होता है ? 3

What is space wave propagation ? Which systems of communication use space waves ? What is 'radio horizon' of a transmitting antenna of height h ? Why is space wave propagation suitable for frequencies above 40 MHz ?

22. ac वोल्टता $v = v_0 \sin \omega t$ का कोई स्रोत प्रेरकत्व L के किसी शुद्ध प्रेरक के सिरो से संयोजित है । परिपथ में तात्क्षणिक धारा के लिए व्यंजक व्युत्पन्न कीजिए । यह दर्शाइए कि इस परिपथ में औसत शक्ति क्षय शून्य है । 3

A source of ac voltage $v = v_0 \sin \omega t$, is connected across a pure inductor of inductance L . Derive the expressions for the instantaneous current in the circuit. Show that average power dissipated in the circuit is zero.

खण्ड द

SECTION D

23. सुनील और उसके माता-पिता अपनी कार से अपने गाँव जा रहे थे । रास्ते में उसकी माताजी ने निचले भवनों की छतों पर धूसर रंग के कुछ पैनल लगे देखे । उन्होंने सुनील से इन पैनलों के बारे में पूछा कि ये क्या हैं । सुनील ने अपनी माताजी को बताया कि ये सौर पैनल हैं ।

- (a) सुनील और उसकी माताजी द्वारा प्रदर्शित मूल्य क्या थे ? प्रत्येक का एक-एक मूल्य लिखिए ।
- (b) किस प्रकार सौर पैनलों का उपयोग अत्यधिक उपयोगी सिद्ध होगा ?
- (c) सौर पैनलों में उपयोग होने वाली अर्धचालक युक्ति का नाम लिखिए । आरेख की सहायता से संक्षेप में इस युक्ति की क्रियाविधि की व्याख्या कीजिए । 4

Sunil and his parents were travelling to their village in their car. On the way his mother noticed some grey coloured panels installed on the roof of a low building. She enquired from Sunil what those panels were and Sunil told his mother that those were solar panels.

- (a) What were the values displayed by Sunil and his mother ? State one value for each.
- (b) In what way would the use of solar panels prove to be very useful ?
- (c) Name the semiconductor device used in solar panels. Briefly explain with the help of a diagram, how this device works.

खण्ड य
SECTION E

24. (a) वक्रता त्रिज्या R के किसी उत्तल गोलीय पृष्ठ, जो अपवर्तनांक n_1 और n_2 ($n_2 > n_1$) के दो माध्यमों को पृथक् करता है, के मुख्य अक्ष पर कोई बिन्दुकित बिम्ब स्थित है। विरल से सघन माध्यम में उत्तल गोलीय पृष्ठ पर अपवर्तन के लिए किरण आरेख खींचिए और बिम्ब दूरी (u), प्रतिबिम्ब दूरी (v) तथा वक्रता त्रिज्या (R) के बीच संबंध व्युत्पन्न कीजिए।
- (b) किसी अभिसारी लेंस की वायु में फोकस दूरी 20 cm है। यह लेंस अपवर्तनांक 1.6 के पदार्थ का बना है। यदि यह किसी द्रव जिसका अपवर्तनांक 1.3 है, में डूबा है, तो इसकी नयी फोकस दूरी ज्ञात कीजिए।

5

अथवा

- (a) किसी काँच के प्रिज़्म से गुज़रने वाले प्रकाश के अपवर्तन के लिए किरण आरेख खींचिए और अतः प्रिज़्म के अपवर्तनांक μ , प्रिज़्म कोण और न्यूनतम विचलन कोण के बीच संबंध प्राप्त कीजिए।
- (b) उस प्रकाश की किरण के लिए आपतन कोण का मान निर्धारित कीजिए, जो अपवर्तनांक $\mu_1 = \sqrt{2}$ के माध्यम से किसी अपवर्तनांक $\mu_2 = 1$ के माध्यम में इस प्रकार गमन करती है कि यह पृथक् करने वाले पृष्ठ को ठीक-ठीक स्पर्श करती है।
- (a) A point object is placed on the principal axis of a convex spherical surface of radius of curvature R , which separates the two media of refractive indices n_1 and n_2 ($n_2 > n_1$). Draw the ray diagram and deduce the relation between the object distance (u), image distance (v) and the radius of curvature (R) for refraction to take place at the convex spherical surface from rarer to denser medium.
- (b) A converging lens has a focal length of 20 cm in air. It is made of a material of refractive index 1.6. If it is immersed in a liquid of refractive index 1.3, find its new focal length.

5

OR

- (a) Draw the ray diagram showing refraction of light through a glass prism and hence obtain the relation between the refractive index μ of the prism, angle of prism and angle of minimum deviation.
- (b) Determine the value of the angle of incidence for a ray of light travelling from a medium of refractive index $\mu_1 = \sqrt{2}$ into the medium of refractive index $\mu_2 = 1$, so that it just grazes along the surface of separation.

25. (a) (i) पोटेंशियोमीटर का कार्यकारी सिद्धान्त लिखिए । किसी दिए गए पोटेंशियोमीटर को और अधिक सुग्राही किस प्रकार बनाया जा सकता है ?
- (ii) नीचे दो पोटेंशियोमीटरों के लिए ग्राफ दर्शाए गए हैं । कारण सहित उल्लेख कीजिए कि इन दो पोटेंशियोमीटरों A अथवा B में से कौन-सा अधिक सुग्राही है ।

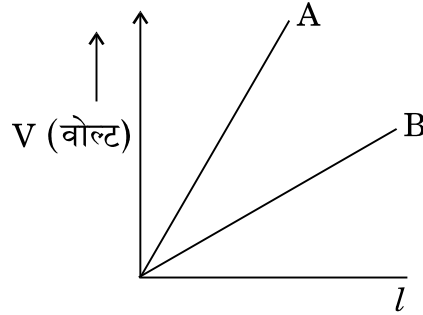

- (b) समान पदार्थ और समान लम्बाई के दो धातु के तार P_1 और P_2 जिनके अनुप्रस्थ-काट के क्षेत्रफल A_1 और A_2 हैं, एक-दूसरे से जुड़े हैं और वि.वा.बल के किसी स्रोत से संयोजित हैं । इन दोनों तारों से मुक्त इलेक्ट्रॉनों के अपवाह वेगों का अनुपात ज्ञात कीजिए जबकि ये तार (i) श्रेणीक्रम में, और (ii) पार्श्व (समांतर क्रम) में संयोजित हैं ।

5

अथवा

- (a) किसी संधारित्र की धारिता की परिभाषा दीजिए । निर्वात में किसी समान्तर पट्टिका संधारित्र की धारिता के लिए, पट्टिकाओं के क्षेत्रफल A तथा पट्टिकाओं के बीच पृथकन d के पदों में व्यंजक व्युत्पन्न कीजिए ।
- (b) परावैद्युतांक K के पदार्थ के किसी स्लैब का उतना ही क्षेत्रफल है, जितना किसी समान्तर पट्टिका संधारित्र की पट्टिकाओं का है परन्तु उसकी मोटाई $\frac{3d}{4}$ है । परावैद्युतांक के साथ धारिता और बिना परावैद्युतांक के धारिता का अनुपात ज्ञात कीजिए ।

5

- (a) (i) State the principle on which a potentiometer works. How can a given potentiometer be made more sensitive ?
- (ii) In the graph shown below for two potentiometers, state with reason which of the two potentiometers, A or B, is more sensitive.

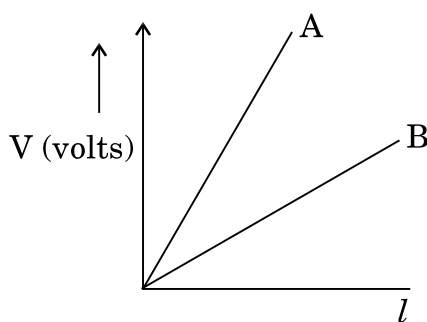

- (b) Two metallic wires, P_1 and P_2 of the same material and same length but different cross-sectional areas, A_1 and A_2 are joined together and connected to a source of emf. Find the ratio of the drift velocities of free electrons in the two wires when they are connected (i) in series, and (ii) in parallel.

OR

- (a) Define the capacitance of a capacitor. Obtain the expression for the capacitance of a parallel plate capacitor in vacuum in terms of plate area A and separation d between the plates.
- (b) A slab of material of dielectric constant K has the same area as the plates of a parallel plate capacitor but has a thickness $\frac{3d}{4}$. Find the ratio of the capacitance with dielectric inside it to its capacitance without the dielectric.



26. (a) फैराडे का विद्युत्-चुम्बकीय प्रेरण का नियम लिखिए ।

(b) चित्र में दर्शाए अनुसार 12 cm त्रिज्या और 8.5Ω प्रतिरोध के किसी वृत्ताकार पाश से गुजरने वाले चुम्बकीय क्षेत्र में समय के साथ परिवर्तन होता है । चुम्बकीय क्षेत्र पाश के समतल के लम्बवत् है । पाश में प्रेरित धारा परिकल्पित कीजिए और समय के फलन के रूप में इसे आलेखित कीजिए ।

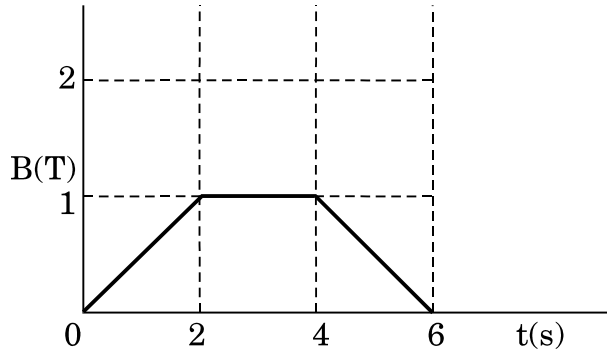

(c) यह दर्शाइए कि लेंज़ का नियम ऊर्जा संरक्षण का निष्कर्ष है ।

5

अथवा

(a) उपयुक्त आरेख की सहायता से किसी उच्चायी ट्रांसफॉर्मर के कार्यकारी सिद्धान्त का वर्णन कीजिए । प्राथमिक और द्वितीयक कुण्डलियों में फेरों की संख्या और निवेशी व निर्गत परिपथों में धाराओं के पदों में निवेशी और निर्गत वोल्टताओं के बीच संबंध प्राप्त कीजिए ।

(b) 90% दक्षता के किसी उच्चायी ट्रांसफॉर्मर के लिए निवेशी धारा 15 A और निवेशी वोल्टता 100 V दी गयी है । यदि निर्गत धारा 3 A है, तो निर्गत शक्ति और द्वितीयक में वोल्टता ज्ञात कीजिए ।

5

- (a) State Faraday's law of electromagnetic induction.
- (b) The magnetic field through a circular loop of wire 12 cm in radius and 8.5Ω resistance, changes with time as shown in the figure. The magnetic field is perpendicular to the plane of the loop. Calculate the induced current in the loop and plot it as a function of time.

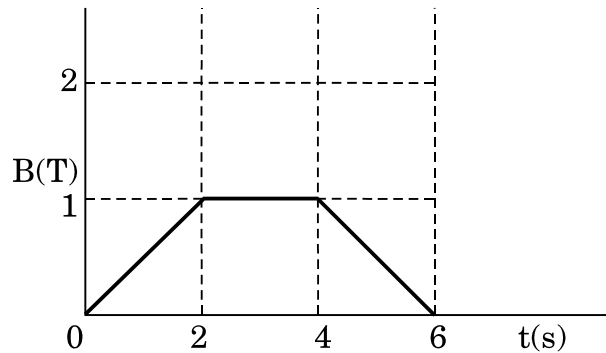

- (c) Show that Lenz's law is a consequence of conservation of energy.

OR

- (a) Describe, with the help of a suitable diagram, the working principle of a step-up transformer. Obtain the relation between input and output voltages in terms of the number of turns of primary and secondary windings and the currents in the input and output circuits.
- (b) Given the input current 15 A and the input voltage of 100 V for a step-up transformer having 90% efficiency, find the output power and the voltage in the secondary if the output current is 3 A.

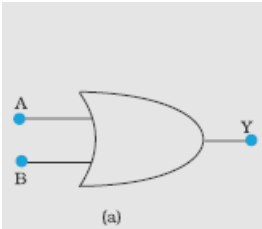

MARKING SCHEME

Q. No.	Expected Answer/ Value Points	Marks	Total Marks																						
Q1	<table border="1"> <tr> <td>For writing yes</td> <td>1/2</td> </tr> <tr> <td>Justification</td> <td>1/2</td> </tr> </table> <p>Yes</p> <p>Justification: $m \propto \frac{1}{f_0 f_e}$</p> <p>And focal length depends on colour/μ.</p>	For writing yes	1/2	Justification	1/2	1/2 1/2	1																		
For writing yes	1/2																								
Justification	1/2																								
Q2	<table border="1"> <tr> <td>Writing Yes</td> <td>1/2</td> </tr> <tr> <td>Reason</td> <td>1/2</td> </tr> </table> <p>Yes</p> <p>Reason - $v_{blue} > v_{red}$</p> <p>[Alternatively: Energy of blue light photon is greater than energy of red light photon.]</p>	Writing Yes	1/2	Reason	1/2	1/2 1/2	1																		
Writing Yes	1/2																								
Reason	1/2																								
Q3	<table border="1"> <tr> <td>Logic Symbol</td> <td>1/2</td> </tr> <tr> <td>Truth Table</td> <td>1/2</td> </tr> </table> <div style="display: flex; justify-content: space-around; align-items: center;"> <div style="text-align: center;">  <p>(a)</p> </div> <div style="text-align: center;"> <table border="1"> <thead> <tr> <th colspan="2">Input</th> <th>Output</th> </tr> <tr> <th>A</th> <th>B</th> <th>Y</th> </tr> </thead> <tbody> <tr> <td>0</td> <td>0</td> <td>0</td> </tr> <tr> <td>0</td> <td>1</td> <td>1</td> </tr> <tr> <td>1</td> <td>0</td> <td>1</td> </tr> <tr> <td>1</td> <td>1</td> <td>1</td> </tr> </tbody> </table> <p>(b)</p> </div> </div>	Logic Symbol	1/2	Truth Table	1/2	Input		Output	A	B	Y	0	0	0	0	1	1	1	0	1	1	1	1	1/2 1/2	1
Logic Symbol	1/2																								
Truth Table	1/2																								
Input		Output																							
A	B	Y																							
0	0	0																							
0	1	1																							
1	0	1																							
1	1	1																							
Q4	<p>i) $V_A > V_B$</p> <p>ii) $V_A < V_B$</p>	1/2 1/2	1																						
Q5	<table border="1"> <tr> <td>Formula</td> <td>1</td> </tr> </table> $c = \frac{1}{\sqrt{\mu\epsilon}}$ <p>[Alternatively,</p> $c = \frac{1}{\sqrt{\mu_0 \mu_r \epsilon_0 \epsilon_r}}]$	Formula	1	1	1																				
Formula	1																								
Q6	<table border="1"> <tr> <td>Formula</td> <td>1/2</td> </tr> <tr> <td>Image distance for $u \leq f + x$</td> <td>1/2</td> </tr> <tr> <td>Image distance where $x \leq f$</td> <td>1</td> </tr> </table> $\frac{1}{v} + \frac{1}{u} = \frac{1}{f} \quad (f \text{ is negative})$	Formula	1/2	Image distance for $ u \leq f + x $	1/2	Image distance where $ x \leq f $	1	1/2																	
Formula	1/2																								
Image distance for $ u \leq f + x $	1/2																								
Image distance where $ x \leq f $	1																								

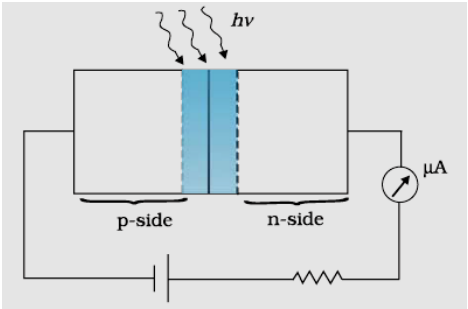

	<p> $U = -f \Rightarrow \frac{1}{v} = 0 \Rightarrow v = \infty$ $U = -2f \Rightarrow \frac{1}{v} = \frac{-1}{2f} \Rightarrow v = -2f$ Hence if $-2f < u < -f \Rightarrow -2f < v < \infty$ </p> <p><u>[Alternatively</u></p> <p> $2f > u > f$ $-\frac{1}{2f} > -\frac{1}{u} > -\frac{1}{f}$ $\frac{1}{f} - \frac{1}{2f} > \frac{1}{f} - \frac{1}{u} > \frac{1}{f} - \frac{1}{f}$ $\frac{1}{2f} < \frac{1}{v} < 0$ $2f < v < \infty$]</p> <p style="text-align: center;">OR</p>	<p>1/2</p> <p>1/2</p> <p>1/2</p> <p>1/2</p> <p>1/2</p>	<p>2</p>						
	<table border="1" style="width: 100%;"> <tr> <td>(a) Formula for magnification</td> <td style="text-align: right;">1/2</td> </tr> <tr> <td>Conditions for large magnification</td> <td style="text-align: right;">1/2</td> </tr> <tr> <td>(b) Any two reasons</td> <td style="text-align: right;">1/2 + 1/2</td> </tr> </table>	(a) Formula for magnification	1/2	Conditions for large magnification	1/2	(b) Any two reasons	1/2 + 1/2		
(a) Formula for magnification	1/2								
Conditions for large magnification	1/2								
(b) Any two reasons	1/2 + 1/2								
	<p style="text-align: center;">$m = -\frac{f_0}{f_e}$</p> <p>By increasing f_0 / decreasing f_e</p> <p>(a) Any two</p> <ul style="list-style-type: none"> (i) No chromatic aberration. (ii) No spherical aberration. (iii) Mechanical advantage – low weight, easier to support. (iv) Mirrors are easy to prepare. (v) More economical 	<p>1/2</p> <p>1/2</p> <p>1/2 + 1/2</p>	<p>2</p>						
<p>Q7</p>	<table border="1" style="width: 100%;"> <tr> <td>Formulae</td> <td style="text-align: right;">1/2+1/2</td> </tr> <tr> <td>Finding Intensity</td> <td style="text-align: right;">1/2 + 1/2</td> </tr> </table> <p>Phase difference = $\frac{2\pi}{\lambda} \times$ Path difference</p> <p>Path difference $\frac{\lambda}{6} \Rightarrow$ phase difference = $\frac{\pi}{3}$</p> <p>Path difference $\frac{\lambda}{2} \Rightarrow$ phase difference = π</p> <p style="text-align: center;">$I = 4I_0 \cos^2\left(\frac{\phi}{2}\right)$</p> <p>i. $I_1 = 4I_0 \times \frac{3}{4} = 3I_0$</p> <p>ii. $I_2 = 4I_0 \times 0 = 0$</p>	Formulae	1/2+1/2	Finding Intensity	1/2 + 1/2	<p>1/2</p> <p>1/2</p> <p>1/2</p> <p>1/2</p>	<p>2</p>		
Formulae	1/2+1/2								
Finding Intensity	1/2 + 1/2								

<p>Q8</p>	<table border="1" style="width: 100%;"> <tr> <td style="width: 80%;">Circuit Diagram</td> <td style="width: 20%; text-align: right;">1</td> </tr> <tr> <td>Working</td> <td style="text-align: right;">1</td> </tr> </table> <div style="text-align: center; margin: 10px 0;">  </div> <p>When photodiode is illuminated with light (photons), with energy ($h\nu > E_g$), electron-hole pairs are generated near the depletion region of the diode. The direction of electric field is such that electrons reach n-side and holes reach p-side and give current(in reverse direction)</p>	Circuit Diagram	1	Working	1	<p>1</p>	<p>2</p>
Circuit Diagram	1						
Working	1						
<p>Q9</p>	<table border="1" style="width: 100%;"> <tr> <td style="width: 80%;">Distinguishing the two nodes</td> <td style="width: 20%; text-align: right;">($\frac{1}{2} + \frac{1}{2}$)</td> </tr> <tr> <td>One example of each</td> <td style="text-align: right;">($\frac{1}{2} + \frac{1}{2}$)</td> </tr> </table> <p>In point-to-point communication mode, communication takes place over a link between a single transmitter and a single receiver.</p> <p>In the broadcast mode, there are a large number of receivers corresponding to a single transmitter.</p> <p>Example: Point-to-point: telephone (any other)</p> <p style="padding-left: 40px;">Broadcast: T.V., Radio (any other)</p>	Distinguishing the two nodes	($\frac{1}{2} + \frac{1}{2}$)	One example of each	($\frac{1}{2} + \frac{1}{2}$)	<p>$\frac{1}{2}$</p> <p>$\frac{1}{2}$</p> <p>$\frac{1}{2}$</p> <p>$\frac{1}{2}$</p>	<p>2</p>
Distinguishing the two nodes	($\frac{1}{2} + \frac{1}{2}$)						
One example of each	($\frac{1}{2} + \frac{1}{2}$)						
<p>Q10</p>	<table border="1" style="width: 100%;"> <tr> <td style="width: 80%;">Effect on brightness</td> <td style="width: 20%; text-align: right;">1</td> </tr> <tr> <td>Explanation</td> <td style="text-align: right;">1</td> </tr> </table> <p>Brightness decreases</p> <p>Explanation:- Self inductance of solenoid increases; this increases the impedance of the circuit and hence current decreases .</p> <p>(Even if student just writes self inductance increases, award this 1 mark.)</p>	Effect on brightness	1	Explanation	1	<p>1</p> <p>1</p>	<p>2</p>
Effect on brightness	1						
Explanation	1						

Section: C

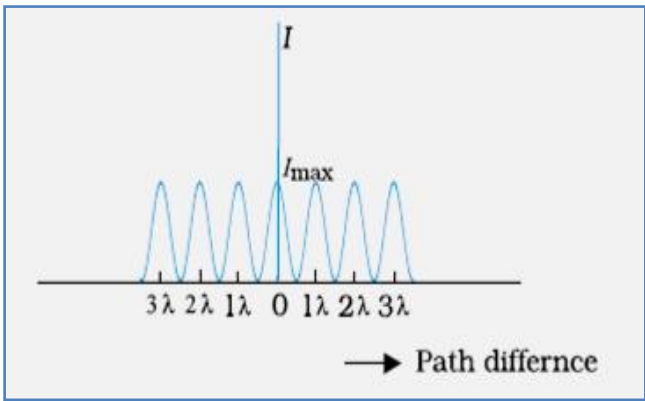
<p>Q11</p>	<table border="1"> <tr> <td>i.</td> <td>Formula</td> <td>$\frac{1}{2}$</td> </tr> <tr> <td></td> <td>Finding ratio</td> <td>1</td> </tr> <tr> <td>ii.</td> <td>Formula</td> <td>$\frac{1}{2}$</td> </tr> <tr> <td></td> <td>Finding ratio</td> <td>1</td> </tr> </table> <p>i. $r = \frac{mv}{qB}$ For proton $r_p = \frac{m_p v}{q_p B}$</p> <p>For α particle $r_\alpha = \frac{m_\alpha v}{q_\alpha B}$</p> $\frac{r_p}{r_\alpha} = \frac{m_p q_\alpha}{q_p m_\alpha} = \frac{1}{2}$ <p>ii. $r = \frac{\sqrt{2mK}}{qB}$</p> $r_p = \frac{\sqrt{2m_p K}}{q_p B}$ $r_\alpha = \frac{\sqrt{2m_\alpha K}}{q_\alpha B}$ $\frac{r_p}{r_\alpha} = \frac{q_\alpha}{q_p} \sqrt{\frac{m_p}{m_\alpha}} = \frac{1}{1}$	i.	Formula	$\frac{1}{2}$		Finding ratio	1	ii.	Formula	$\frac{1}{2}$		Finding ratio	1	<p>$\frac{1}{2}$</p> <p>1</p> <p>$\frac{1}{2}$</p> <p>1</p> <p>3</p>	
i.	Formula	$\frac{1}{2}$													
	Finding ratio	1													
ii.	Formula	$\frac{1}{2}$													
	Finding ratio	1													
<p>Q12</p>	<table border="1"> <tr> <td>Intensity distribution graph for interference</td> <td>1</td> </tr> <tr> <td>Intensity distribution graph for diffraction</td> <td>1</td> </tr> <tr> <td>Any two differences</td> <td>$\frac{1}{2} + \frac{1}{2}$</td> </tr> </table> 	Intensity distribution graph for interference	1	Intensity distribution graph for diffraction	1	Any two differences	$\frac{1}{2} + \frac{1}{2}$	<p>1</p>							
Intensity distribution graph for interference	1														
Intensity distribution graph for diffraction	1														
Any two differences	$\frac{1}{2} + \frac{1}{2}$														

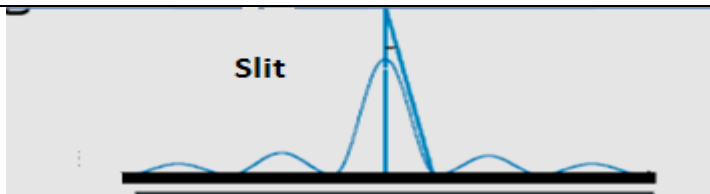

1

Any two differences

S.No	Interference	Diffraction
1	All fringes are equal in width	Central bright maxima is twice as wide as the other maxima.
2	Intensity of all bright fringes is same.	Intensity falls as we go to successive maxima away from centre.
3	Conditions for maxima and minima are opposite to diffraction pattern.	Condition for maxima and minima are opposite to interference pattern.
4	Pattern is formed by superposing two waves originating from two narrow slits.	Diffraction pattern is a superposition of wavelets originating from different parts of a single wavefront.

1/2 + 1/2

3

Q13

Derivation of expression for electric field	2
Proving that there is no electric field between plates	1

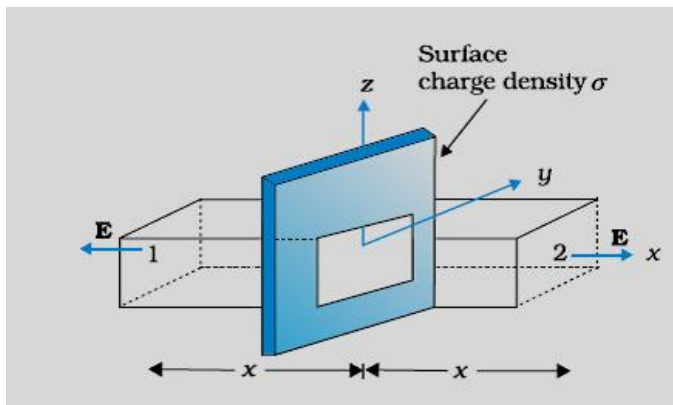

1/2

By Gauss's law $\oint \vec{E} \cdot d\vec{s} = \frac{q}{\epsilon_0}$

1/2

$\therefore 2EA = \frac{\sigma A}{\epsilon_0}$

1/2

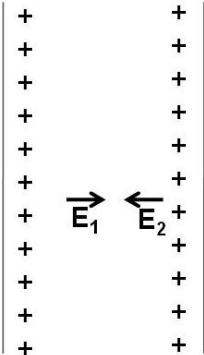
	<p>$\therefore E = \frac{\sigma}{2\epsilon_0}$ or $\vec{E} = \frac{\sigma}{2\epsilon_0} A$</p> <p>Electric field between two identical charged sheets</p> <div style="text-align: center;">  </div> <p>\therefore Both the sheets have same charge density, their electric fields will be equal and opposite in the region between the two sheets.</p> <p>Hence the net field is zero.</p> <p>[Alternatively $E_1 = \frac{\sigma}{2\epsilon_0}$ $E_2 = -\frac{\sigma}{2\epsilon_0}$ Resultant electric field between the plates = $E_1 + E_2$ $= \frac{\sigma}{2\epsilon_0} - \frac{\sigma}{2\epsilon_0}$ $= 0$]</p>	<p>$\frac{1}{2}$</p> <p>$\frac{1}{2}$</p> <p>$\frac{1}{2}$</p>	<p>3</p>
--	---	---	----------

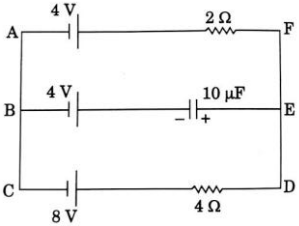
<p>Q14</p>	<table border="1" style="width: 100%;"> <tr> <td>Value of current</td> <td style="text-align: right;">1</td> </tr> <tr> <td>Value of voltage</td> <td style="text-align: right;">1</td> </tr> <tr> <td>Value of charge</td> <td style="text-align: right;">1</td> </tr> </table> <div style="text-align: center;">  </div> <p>In loop ACDFFA</p>	Value of current	1	Value of voltage	1	Value of charge	1		
Value of current	1								
Value of voltage	1								
Value of charge	1								

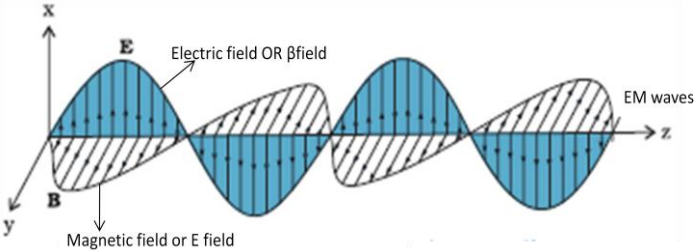
	$I = \left[\frac{8 - 4}{4 + 2} \right] A = \frac{2}{3} A$ $V_{AF} = V_{BE}$ $\Rightarrow 4 - 2 \times \frac{2}{3} = 4 - V_c$ $\Rightarrow V_c = \frac{4}{3} V$ <p>Charge, $Q = CV_c$ $Q = (10\mu F \times \frac{4}{3})$ $= 13.33 \mu C$</p>	<p>1</p> <p>1/2</p> <p>1/2</p> <p>1</p>	<p>3</p>						
<p>Q15</p>	<table border="1" data-bbox="211 721 999 824"> <tr> <td>(a) Explanation of production of em waves</td> <td>1 1/2</td> </tr> <tr> <td>(b) Depiction of em waves</td> <td>1 1/2</td> </tr> </table> <p>(a) An oscillating charge produces an oscillating electric field in space, which produces an oscillating magnetic field, which in turn, is a source of oscillating electric field and so on. Thus, oscillating electric and magnetic fields generate each other, they then propagate in space.</p> <p>[Alternatively, if a student writes Electromagnetic waves are produced by oscillating electric and magnetic fields / oscillating charges produce em waves. Award 1 mark]</p> 	(a) Explanation of production of em waves	1 1/2	(b) Depiction of em waves	1 1/2	<p>1 1/2</p> <p>1 1/2</p>	<p>3</p>		
(a) Explanation of production of em waves	1 1/2								
(b) Depiction of em waves	1 1/2								
<p>Q16</p>	<table border="1" data-bbox="211 1520 999 1647"> <tr> <td>(a) Derivation</td> <td>2</td> </tr> <tr> <td>(b) Formula</td> <td>1/2</td> </tr> <tr> <td>Calculation</td> <td>1/2</td> </tr> </table> <p>(a) $N(t) = N_0 e^{-\lambda t}$ When $t = T_{1/2} \Rightarrow N(t) = \frac{N_0}{2}$ $\therefore \frac{N_0}{2} = N_0 e^{-\lambda T_{1/2}}$</p>	(a) Derivation	2	(b) Formula	1/2	Calculation	1/2	<p>1/2</p> <p>1/2</p>	
(a) Derivation	2								
(b) Formula	1/2								
Calculation	1/2								

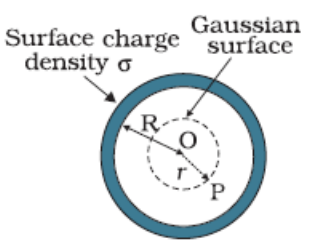
	$\Rightarrow \frac{1}{2} = e^{-\lambda T_{1/2}}$ $\Rightarrow -\lambda T_{1/2} = -\ln 2$ $\Rightarrow T_{1/2} = \frac{\ln 2}{\lambda} = \frac{0.693}{\lambda}$ <p>(b) $\frac{N}{N_0} = \left(\frac{1}{2}\right)^n \quad n = \frac{t}{T_{1/2}}$</p> <p>Given $\frac{N}{N_0} = \frac{1}{4} = \left(\frac{1}{2}\right)^n$</p> $\left(\frac{1}{2}\right)^n = \left(\frac{1}{2}\right)^2$ <p>\therefore Number of half lives = 2</p> $\Rightarrow \frac{1000}{T_{1/2}} = 2$ $\Rightarrow T_{1/2} = \frac{1000}{2} = 500 \text{ years}$ <p>[<u>Alternatively</u> 1000 years = 2 half lives \therefore Half life = 500 years]</p>	<p>$\frac{1}{2}$</p> <p>$\frac{1}{2}$</p> <p>$\frac{1}{2}$</p> <p>$\frac{1}{2}$</p>	<p>3</p>								
<p>Q17</p>	<table border="1" style="width: 100%; border-collapse: collapse;"> <tr> <td style="padding: 5px;">Expression for electric field</td> <td style="text-align: right; padding: 5px;">$\frac{1}{2}$</td> </tr> <tr> <td style="padding: 5px;">Expression for potential</td> <td style="text-align: right; padding: 5px;">$\frac{1}{2}$</td> </tr> <tr> <td style="padding: 5px;">Plot of graph (E Vs r)</td> <td style="text-align: right; padding: 5px;">$\frac{1}{2}$</td> </tr> <tr> <td style="padding: 5px;">Plot of graph (V Vs r)</td> <td style="text-align: right; padding: 5px;">$\frac{1}{2}$</td> </tr> </table> <div style="text-align: center; margin: 10px 0;">  </div> <p>By Gauss theorem</p> $\oint \vec{E} \cdot d\vec{s} = \frac{q}{\epsilon_0}$ <p>$q = 0$ in interval $0 < x < R$</p> $\Rightarrow E = 0$	Expression for electric field	$\frac{1}{2}$	Expression for potential	$\frac{1}{2}$	Plot of graph (E Vs r)	$\frac{1}{2}$	Plot of graph (V Vs r)	$\frac{1}{2}$	<p>$\frac{1}{2}$</p> <p>$\frac{1}{2}$</p> <p>$\frac{1}{2}$</p>	
Expression for electric field	$\frac{1}{2}$										
Expression for potential	$\frac{1}{2}$										
Plot of graph (E Vs r)	$\frac{1}{2}$										
Plot of graph (V Vs r)	$\frac{1}{2}$										

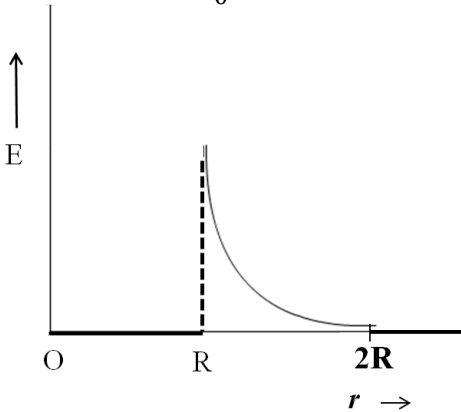
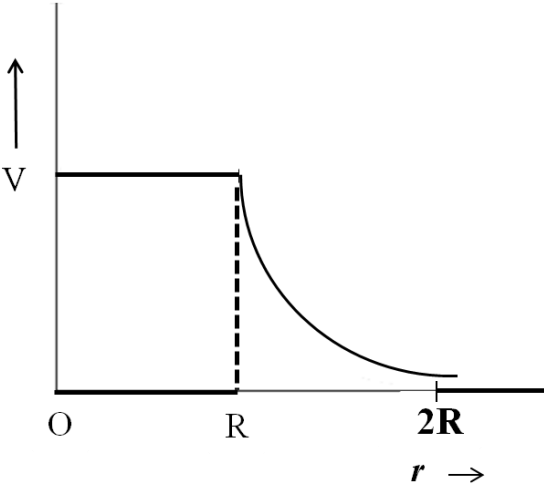
	<p>$E = -\frac{dV}{dr}$</p> <p>$\Rightarrow V = \text{constant} = \frac{1}{4\pi\epsilon_0} \frac{Q}{R}$</p>   <p>[Even if a student draws E and V for $0 < r < R$ award $\frac{1}{2} + \frac{1}{2}$ mark.]</p>	<p>$\frac{1}{2}$</p> <p>$\frac{1}{2}$</p> <p>$\frac{1}{2}$</p>	<p>3</p>				
<p>Q18</p>	<table border="1" style="width: 100%;"> <tr> <td style="padding: 5px;">Bohr quantum condition</td> <td style="text-align: right; padding: 5px;">$\frac{1}{2}$</td> </tr> <tr> <td style="padding: 5px;">Expression for Time period</td> <td style="text-align: right; padding: 5px;">$2\frac{1}{2}$</td> </tr> </table> <p>$mvr = \frac{nh}{2\pi}$ ----- Bohr postulate</p> <p>Also, $\frac{mv^2}{r} = \frac{1}{4\pi\epsilon_0} \frac{e^2}{r^2}$</p> <p>$\Leftrightarrow mv^2 r = \frac{e^2}{4\pi\epsilon_0}$</p> <p>$\therefore v = \frac{e^2}{4\pi\epsilon_0} \times \frac{2\pi}{nh} = \frac{e^2}{2\epsilon_0 nh}$</p>	Bohr quantum condition	$\frac{1}{2}$	Expression for Time period	$2\frac{1}{2}$	<p>$\frac{1}{2}$</p> <p>$\frac{1}{2}$</p> <p>$\frac{1}{2}$</p> <p>$\frac{1}{2}$</p>	
Bohr quantum condition	$\frac{1}{2}$						
Expression for Time period	$2\frac{1}{2}$						

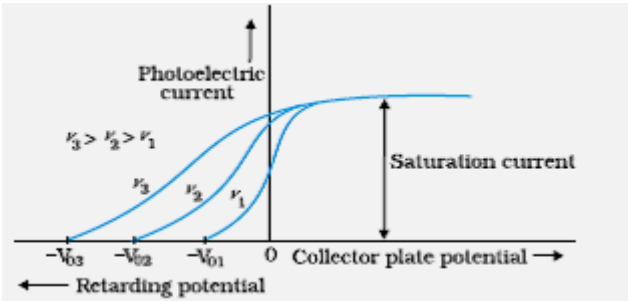
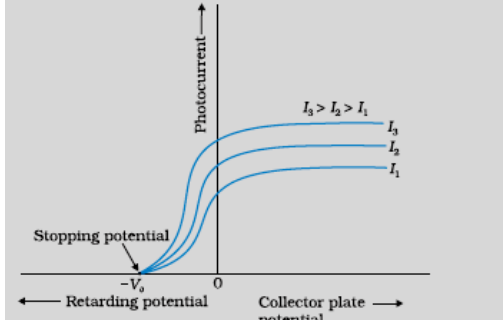
	$T = \frac{2\pi r}{v} = \frac{2\pi mvr}{mv^2}$ $= \frac{2\pi \left(\frac{nh}{2\pi}\right)}{m \left(\frac{e^2}{2\epsilon_0 nh}\right)^2}$ $= \frac{4n^3 h^3 \epsilon_0^2}{me^4}$ <p>(Also accept if the student calculates T by obtaining expressions for both v and r.)</p>	<p>1/2</p> <p>1/2</p>	<p>3</p>
<p>Q19</p>	<p>a) Graph of photo current vs collector potential for different frequencies 1</p> <p>b) Einstein's photo electric equation 1/2 Explanation of graph 1/2</p> <p>c) Graph of photocurrent with collector potential for different intensities 1</p> <div style="margin-top: 20px;"> <p>(a)</p>  </div> <p>(b) According to Einstein's photoelectric equation</p> $K_{max} = hv - \phi_0$ <p>If V_0 is stopping potential then</p> $eV_0 = hv - \phi_0$ <p>Thus for different value of frequency (ν) there will be a different value of cut off potential V_0.</p> <div style="margin-top: 20px;"> <p>(c)</p>  </div>	<p>1</p> <p>1/2</p> <p>1/2</p> <p>1</p>	<p>3</p>

Q20

Biot Savart's Law	½ mark
Deduction of Expression	2 marks
Direction of magnetic field	½ mark

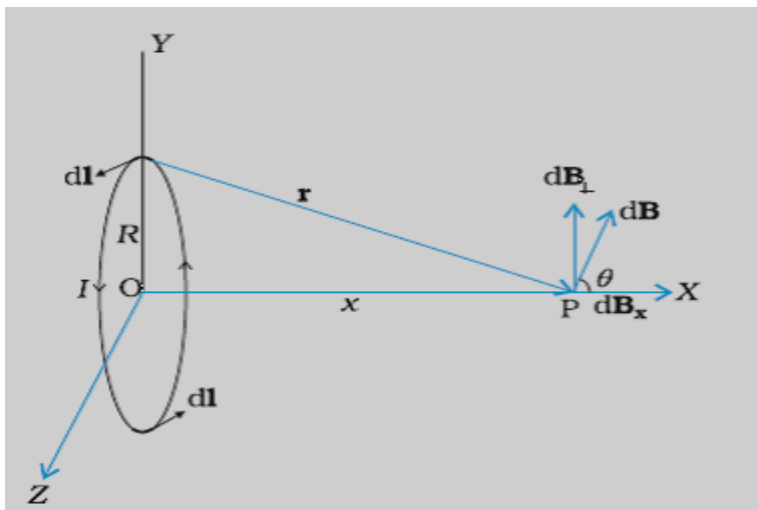

½

$$\vec{dB} = \frac{\mu_0}{4\pi} I \frac{d\vec{l} \times \vec{r}}{r^3}$$

[OR $dB = \frac{\mu_0}{4\pi} \frac{Idl}{r^2}$]

½

Here $r^2 = x^2 + R^2$

$$dB = \frac{\mu_0}{4\pi} \frac{I dl}{x^2 + R^2}$$

½

$$\sum dB_{\perp} = 0$$

$$dB_x = dB \cos \theta \text{ where } \cos \theta = \frac{R}{(x^2 + R^2)^{1/2}}$$

½

$$dB_x = \frac{\mu_0 Idl}{4\pi} \frac{R}{(x^2 + R^2)^{3/2}}$$

$$\vec{B} = \int dB_x \hat{i} = \frac{\mu_0 IR^2}{2(x^2 + R^2)^{3/2}} \hat{i}$$

½

Direction- Can be determined by right hand thumb rule.
[Alternatively: By using vector form of Biot Savart law]

½

3

OR

	<p>(i) Magnitude of magnetic field at A 1 Direction of magnetic field at A ½ Magnitude of magnetic force on conductor 2 1 Direction of magnitude force on conductor 2 ½</p>		
	<p>(i) $B_2 = \frac{\mu_0}{4\pi} \frac{2(3I)}{r} = \frac{\mu_0}{4\pi} \left(\frac{6I}{r}\right)$ into the plane of the paper/(⊗). ½</p> <p>$B_3 = \frac{\mu_0}{4\pi} \frac{2(4I)}{3r} = \frac{\mu_0}{4\pi} \left(\frac{8I}{3r}\right)$ out of the plane of the paper/(⊙). ½</p> <p>$B_A = B_2 - B_3$ into the paper. $= \frac{\mu_0}{4\pi} \left(\frac{10I}{3r}\right)$ into the plane of the paper.(⊗) ½</p> <p>(ii) $F_{21} = \frac{\mu_0}{4\pi} \frac{2I(3I)}{r}$ away from wire1 (/towards 3) ½</p> <p>$F_{23} = \frac{\mu_0}{4\pi} \frac{2(3I)(4I)}{2r}$ away from wire 3 (towards 1) ½</p> <p>$F_{\text{net}} = F_{23} - F_{21}$ towards wire1 $= \frac{\mu_0}{4\pi} \frac{6(I)^2}{r}$ towards wire 1 ½</p>		3
Q21	<p>Definition of space wave propagation 1 Naming system of communication ½ Definition of radio horizon ½ Explanation 1</p>		
	<p>Propagation of waves, along a straight path from the transmitting antenna to receiving antenna, using line of sight (LOC) communication is called space wave propagation. 1</p> <p>Relevant system of communication: Television broadcast, microwave links and satellite communication (any one) ½</p> <p>‘Radio horizon’ equals the distance between the transmitting antenna and the point on the earth where the direct waves get blocked due to the curvature of the earth. ½ [Also accept $d = \sqrt{2hR}$; h = height of transmitting antenna, R = Radius of the earth.]</p> <p>At frequencies above 40 MHz, relatively smaller antennas are needed and communication is essentially limited to line of 1</p>		

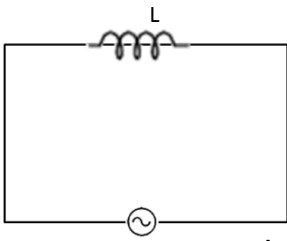

	<p>sight paths.</p> <p>[Alternatively, At frequencies (more than 40 MHz), e.m. waves do not get bent or reflected by ionosphere. Therefore space wave propagation has to be used for frequencies above 40 MHz.]</p>	<p>1</p>	<p>3</p>										
<p>Q22</p>	<table border="1" style="width: 100%; border-collapse: collapse;"> <tr> <td style="padding: 5px;">Derivation of instantaneous current</td> <td style="text-align: right; padding: 5px;">2</td> </tr> <tr> <td style="padding: 5px;">Derivation of average power dissipated</td> <td style="text-align: right; padding: 5px;">1</td> </tr> </table> <p>Given $V = V_0 \sin \omega t$ $V = L \frac{di}{dt} \Rightarrow di = \frac{V}{L} dt$</p> <div style="text-align: center;">  <p style="margin-left: 100px;">$v = v_0 \sin \omega t$</p> </div> <p>$\therefore di = \frac{V_0}{L} \sin \omega t dt$</p> <p>Integrating $i = -\frac{V_0}{\omega L} \cos \omega t$ $\therefore i = -\frac{V_0}{\omega L} \sin(\pi/2 - \omega t) = I_0 \sin(\pi/2 - \omega t)$</p> <p>where $I_0 = \frac{V_0}{\omega L}$</p> <p>Average power</p> $P_{av} = \int_0^T v i dt$ $= \frac{-V_0^2}{\omega L} \int_0^T \sin \omega t \cos \omega t dt$ $= \frac{-V_0^2}{2\omega L} \int_0^T \sin(2\omega t) dt$ <p>$= 0$</p>	Derivation of instantaneous current	2	Derivation of average power dissipated	1	<p>$\frac{1}{2}$</p> <p>$\frac{1}{2}$</p> <p>$\frac{1}{2}$</p> <p>$\frac{1}{2}$</p> <p>$\frac{1}{2}$</p>	<p>3</p>						
Derivation of instantaneous current	2												
Derivation of average power dissipated	1												
<p>Q23</p>	<table border="1" style="width: 100%; border-collapse: collapse;"> <tr> <td style="padding: 5px;">Values displayed</td> <td style="text-align: right; padding: 5px;">1 + 1</td> </tr> <tr> <td style="padding: 5px;">Usefulness of solar panels</td> <td style="text-align: right; padding: 5px;">$\frac{1}{2}$</td> </tr> <tr> <td style="padding: 5px;">Name of semiconductor device</td> <td style="text-align: right; padding: 5px;">$\frac{1}{2}$</td> </tr> <tr> <td style="padding: 5px;">Diagram of the device</td> <td style="text-align: right; padding: 5px;">$\frac{1}{2}$</td> </tr> <tr> <td style="padding: 5px;">Working of device</td> <td style="text-align: right; padding: 5px;">$\frac{1}{2}$</td> </tr> </table> <p>a) Value displayed by mother:</p>	Values displayed	1 + 1	Usefulness of solar panels	$\frac{1}{2}$	Name of semiconductor device	$\frac{1}{2}$	Diagram of the device	$\frac{1}{2}$	Working of device	$\frac{1}{2}$		
Values displayed	1 + 1												
Usefulness of solar panels	$\frac{1}{2}$												
Name of semiconductor device	$\frac{1}{2}$												
Diagram of the device	$\frac{1}{2}$												
Working of device	$\frac{1}{2}$												

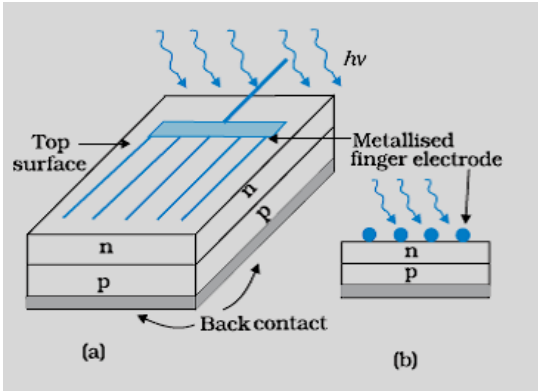
	<p>Inquisitive / scientific temperament / wants to learn / any other. Value displayed by Sunil: Knowledgeable / helpful/ considerate</p> <p>b) Provide clean / green energy Reduces dependence on fossil fuels, Environment friendly energy source.</p> <p>c) Solar Cell</p>  <p>(full marks for any one figure out of a &b)</p> <p>Working: When light falls on the device the solar cell generates an emf.</p>	<p>1 1 1/2 1/2 1/2 1/2</p>	<p>4</p>
--	--	---	----------

<p>Q24</p>	<p>a) Diagram 1 Derivation of the relation 2 b) Lens Maker's formula – 1/2 Calculation of f in water – 1 1/2</p>	<p>1</p>	
------------	---	----------	--

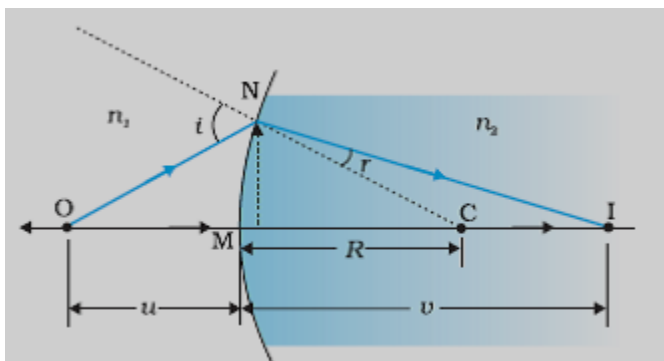

For small angles

$$\tan \angle NOM = \frac{MN}{OM} : \tan \angle NCM = \frac{MN}{NC}$$

$$\text{and } \tan \angle NIM = \frac{MN}{MI}$$

For $\triangle NOC$, i is exterior angle, therefore

$$i = \angle NOM + \angle NCM = \frac{MN}{OM} + \frac{MN}{MC}$$

$$\text{Similarly } r = \frac{MN}{MC} - \frac{MN}{MI}$$

For small angles Snells law can be written as

$$n_1 i = n_2 r$$

$$\therefore \frac{n_1}{OM} + \frac{n_2}{MI} = \frac{n_2 - n_1}{MC}$$

$$\therefore OM = -u, \quad MI = +v \quad MC = +R \quad (\text{using sign conversion})$$

$$\therefore \frac{n_2}{v} - \frac{n_1}{u} = \frac{n_2 - n_1}{R}$$

(b) Lens Maker's formula is

$$\frac{1}{f_a} = \left(\frac{n_2 - 1}{n_1} \right) \left(\frac{1}{R_1} - \frac{1}{R_2} \right)$$

$$\therefore \frac{1}{20} = (1.6 - 1) \left(\frac{1}{R_1} - \frac{1}{R_2} \right)$$

$$\therefore \left(\frac{1}{R_1} - \frac{1}{R_2} \right) = \frac{1}{20 \times 0.6} = \frac{1}{12}$$

Let f be the focal length of the lens in water

$$\therefore \frac{1}{f'} = \frac{1.6 - 1.3}{1.3} \left(\frac{1}{R_1} - \frac{1}{R_2} \right) = \frac{0.3}{12 \times 1.3}$$

$$\text{Or } f' = \frac{120 \times 1.3}{3} = 52 \text{ cm}$$

OR

(a) Diagram	1/2
Obtaining the relation	3
(b) Numerical	1 1/2

1/2

1/2

1/2

1/2

1/2

1/2

1/2

1/2

5



(a)

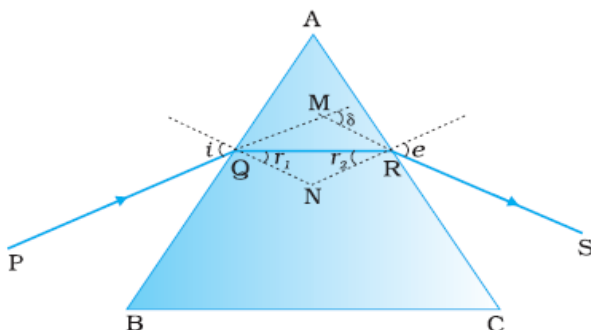

From fig $\angle A + \angle QNR = 180^\circ$ ----- (1)

From triangle ΔQNR $r_1 + r_2 + \angle QNR = 180^\circ$ --(2)

Hence from equ (1) & (2)

$$\therefore \angle A = r_1 + r_2$$

The angle of deviation

$$\delta = (i - r_1) + (e - r_2) = i + e - A$$

At minimum deviation $i = e$ and $r_1 = r_2$

$$\therefore r = \frac{A}{2}$$

And $i = \frac{A + \delta_m}{2}$

Hence refractive index

$$\mu = \frac{\sin i}{\sin r} = \frac{\sin \left(\frac{A + \delta_m}{2} \right)}{\sin A/2}$$

(b) From Snell's law $\mu_1 \sin i = \mu_2 \sin r$

Given $\mu_1 = \sqrt{2}$, $\mu_2 = 1$ and $r = 90^\circ$ (just grazing)

$$\therefore \sqrt{2} \sin i = 1 \sin 90^\circ \Rightarrow \sin i = \frac{1}{\sqrt{2}}$$

$$\text{or } i = 45^\circ$$

1/2

1/2

1/2

1/2

1/2

1/2

1/2

1/2

1/2

1/2

5

Q25

- | | | |
|----|--|-----|
| a) | (i) Principle of potentiometer | 1 |
| | How to increase sensitivity | 1/2 |
| | (ii) Name of potentiometer | 1/2 |
| | Reason | 1/2 |
| b) | Formula | 1/2 |
| | (i) Ratio of drift velocities in series | 1 |
| | (ii) Ratio of drift velocities in parallel | 1 |

a) (i) The potential difference across any length of wire is directly proportional to the length provided current and

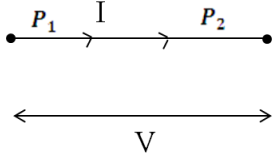
	<p>area of cross section are constant i.e., $E(l) = \phi l$ where ϕ is the potential drop per unit length.</p> <p>It can be made more sensitive by decreasing current in the main circuit /decreasing potential gradient / increasing resistance put in series with the potentiometer wire.</p> <p>ii) Potentiometer B Has smaller value of V/l (slope / potential gradient).</p> <p>b) In series, the current remains the same.</p> <div style="text-align: center;">  <p style="margin-left: 100px;">$I = neA_1V_{d1} = neA_2V_{d2}$ $\therefore \frac{V_{d1}}{V_{d2}} = \frac{A_2}{A_1}$</p> </div> <p>In parallel potential difference is same but currents are different.</p> $V = I_1R_1 = neA_1V_{d1} \frac{\rho l}{A_1} = ne\rho V_{d1}l$ <p>Similarly, $V = I_2R_2 = ne\rho V_{d2}l$</p> $I_1R_1 = I_2R_2$ $\therefore \frac{V_{d1}}{V_{d2}} = 1$ <p style="text-align: center;">OR</p> <table border="1" style="width: 100%; border-collapse: collapse;"> <tr> <td style="padding: 5px;">(a) Definition of capacitance</td> <td style="text-align: right; padding: 5px;">1</td> </tr> <tr> <td style="padding: 5px;"> Obtaining capacitance</td> <td style="text-align: right; padding: 5px;">2</td> </tr> <tr> <td style="padding: 5px;">(b) Ratio of capacitances</td> <td style="text-align: right; padding: 5px;">2</td> </tr> </table> <p>a) Capacitance equals the magnitude of the charge on each plate needed to raise the potential difference between the plates by unity.</p> <p>OR</p> <p>[The capacitance is defined as</p> $c = \frac{q}{V}]$	(a) Definition of capacitance	1	Obtaining capacitance	2	(b) Ratio of capacitances	2	<p>1</p> <p>$\frac{1}{2}$</p> <p>$\frac{1}{2}$</p> <p>$\frac{1}{2}$</p> <p>$\frac{1}{2}$</p> <p>$\frac{1}{2}$</p> <p>$\frac{1}{2}$</p> <p>$\frac{1}{2}$</p> <p>$\frac{1}{2}$</p> <p>5</p> <p>1</p>	
(a) Definition of capacitance	1								
Obtaining capacitance	2								
(b) Ratio of capacitances	2								



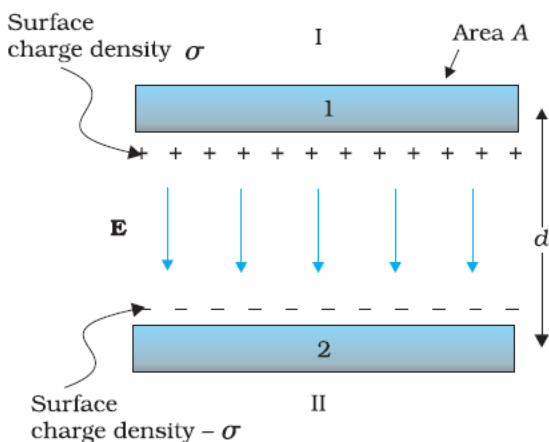

Consider parallel plates of area A
 Plate separation d, the potential difference applied across it is V. The electric field

$$E = \frac{\sigma}{\epsilon_0} = \frac{q}{\epsilon_0 A}$$

Electric field = potential gradient

$$\therefore E = \frac{V}{d}$$

Hence, $\frac{V}{d} = \frac{q}{\epsilon_0 A}$

$$c = \frac{q}{V} = \frac{\epsilon_0 A}{d}$$

1/2

1/2

1/2

1/2

b) The capacitance without dielectric is

$$C_0 = \frac{\epsilon_0 A}{d}$$

The capacitance of the capacitor, partially filled with dielectric constant K, thickness t is

$$c = \frac{\epsilon_0 A}{\left(d - t + \frac{t}{k}\right)}$$

Given $t = \frac{3d}{4} \therefore c = \frac{\epsilon_0 A}{d - \frac{3d}{4}}$

$$\therefore c = \left(\frac{4k}{k+3}\right) \frac{\epsilon_0 A}{d}$$

$$\therefore \frac{c}{C_0} = \frac{4k}{k+3}$$

1/2

1/2

1/2

[Alternatively,

1/2

The capacitance, with dielectric, can be treated as a series combination of two capacitors.



	$C_1 = K \frac{\epsilon_0 A}{\left(\frac{3}{4}d\right)}$ $C_2 = \frac{\epsilon_0 A}{\left(\frac{1}{4}d\right)}$ $\therefore C = \frac{C_1 C_2}{C_1 + C_2} = \frac{\left(K \frac{\epsilon_0 A}{\left(\frac{3}{4}d\right)}\right) \left(\frac{\epsilon_0 A}{\left(\frac{1}{4}d\right)}\right)}{\frac{\epsilon_0 A}{d} \left[\frac{4}{3}k + 4\right]}$ $= \frac{4}{(3+k)} \frac{\epsilon_0 A}{d} = \frac{4}{(3+k)} C_0$ $\frac{c}{c_0} = \frac{4}{k+3} \quad]$	<p>1/2</p> <p>1/2</p> <p>1/2</p> <p>1/2</p>	<p>5</p>								
Q26	<table border="1" style="width: 100%; border-collapse: collapse;"> <tbody> <tr> <td style="padding: 5px;">a) Statement of Faraday's Law</td> <td style="text-align: right; padding: 5px;">1</td> </tr> <tr> <td style="padding: 5px;">b) Calculation of current</td> <td style="text-align: right; padding: 5px;">2</td> </tr> <tr> <td style="padding: 5px;">Graph of current</td> <td style="text-align: right; padding: 5px;">1</td> </tr> <tr> <td style="padding: 5px;">c) Lenz's Law</td> <td style="text-align: right; padding: 5px;">1</td> </tr> </tbody> </table> <p>(a) Faraday's law: The magnitude of the induced emf in a circuit is equal to the time rate of change of magnetic flux through the circuit. [Alternately: $e = -\frac{d\phi}{dt}$]</p> <p>(b) Area = $\pi R^2 = \pi \times 1.44 \times 10^{-2} m^2$ $= 4.5 \times 10^{-2} m^2$</p> <p>For $0 < t < 2$</p> $\text{Emf } e_1 = \frac{d\phi_1}{dt} = -A \frac{dB}{dt}$ $= -4.5 \times 10^{-2} \times \frac{1}{2}$ $I_1 = -\frac{e_1}{R} = -\frac{2.25 \times 10^{-2}}{8.5} = -2.7 \text{ mA}$ <p>For $2 < t < 4$</p> $I_2 = \frac{e_2}{R} = 0$ <p>For $4 < t < 6$</p> $I_3 = -\frac{e_3}{R} = +2.7 \text{ mA}$	a) Statement of Faraday's Law	1	b) Calculation of current	2	Graph of current	1	c) Lenz's Law	1	<p>1</p> <p>1/2</p> <p>1/2</p> <p>1/2</p>	
a) Statement of Faraday's Law	1										
b) Calculation of current	2										
Graph of current	1										
c) Lenz's Law	1										



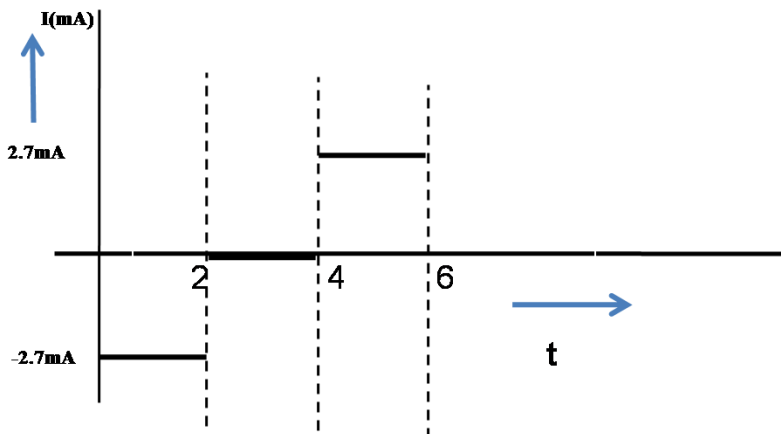

(c)

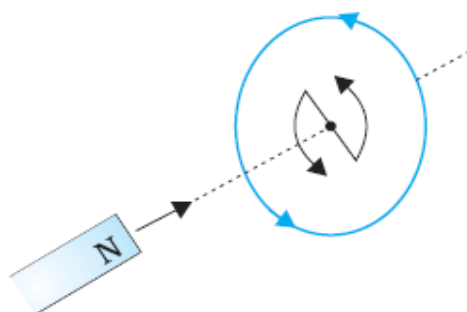

If a north pole of the bar magnet moves towards the coil the magnetic flux through the coil increases. Hence induced current is counter clockwise (to oppose the increase in flux, by producing a north pole.)

In this situation the bar magnet experiences a repulsive force, therefore work has to be done to move the magnet towards the coil. It is this work that gets converted into electrical energy.

OR

a) Diagram	1/2
Principle	1/2
Relation between voltage, number of turns, and Currents	2 1/2
(b) Input power	1/2
Output power	1/2
Output voltage	1/2

1

1

5

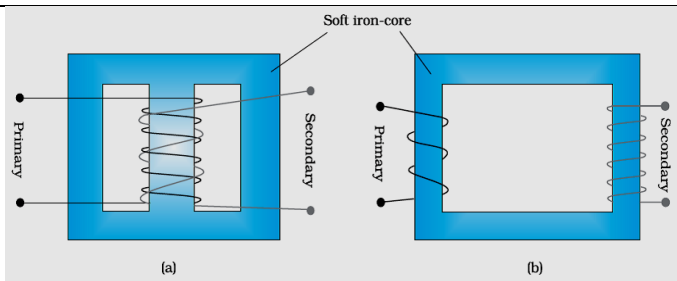

1/2

Working principle

- Whenever current in one coil changes an emf gets induced in the neighboring coil /Principle of mutual induction

1/2

Voltage across secondary.

$$V_s = e_s = -N_s \frac{d\phi}{dt}$$

Voltage across primary

$$V_p = e_p = -N_p \frac{d\phi}{dt}$$

1/2

$$\frac{V_s}{V_p} = \frac{N_s}{N_p} \quad (\text{here } N_s > N_p)$$

1/2

In an Ideal transformer

1/2

Power Input= Power Input

$$I_p V_p = I_s V_s$$

$$\frac{V_s}{V_p} = \frac{I_p}{I_s}$$

1/2

$$\therefore \frac{V_s}{V_p} = \frac{N_s}{N_p} = \frac{I_p}{I_s}$$

1/2

(b) Input power, $P_i = I_i \cdot V_i = 15 \times 100 = 1500 \text{ W}$

Power output, $P_0 = P_i \times \frac{90}{100} = 1350 \text{ W}$
 $\Rightarrow I_0 V_0 = 1350 \text{ W}$

1/2

Output voltage, $V_0 = \frac{1350}{3} \text{ V} = 450 \text{ V}$

1/2

1/2